

2017

Field and laboratory investigation into scour around breakwaters

Fausset, S.

Fausset, S. (2017) 'Field and laboratory investigation into scour around breakwaters', The Plymouth Student Scientist, 10(1), p. 195-238.

<http://hdl.handle.net/10026.1/14144>

The Plymouth Student Scientist
University of Plymouth

All content in PEARL is protected by copyright law. Author manuscripts are made available in accordance with publisher policies. Please cite only the published version using the details provided on the item record or document. In the absence of an open licence (e.g. Creative Commons), permissions for further reuse of content should be sought from the publisher or author.

APPENDIX B

Risk assessment for laboratory work

General Risk Assessment Form (Revised May 2014)

Date:	December 2015	Assessed by:	Sarah Fausset + Dr Jon Miles	Activity/Location	COAST Lab Project work
--------------	---------------	---------------------	------------------------------	--------------------------	------------------------

Hazard	No. at Risk	Controls in Place at Present	L	M	H/E	Further Controls Necessary	Residual Risk Rating	Responsible Person
Drowning /Collapse	2	No lone working		3			1	Student
Injuries from tripping	2	Ensure cables are flush to floor / + neat cable routes First aid kit available No lone working Technicians on site	2			Observe general safety briefing from Technical staff at start.	1	Student
Electric shocks	2	Ensure dry hands before touching electrics and	1			Keep electric equipm	1	Student

		computers.				ent away from tank where possible		
Water based chemicals / bacteria	2	Avoid eating / drinking in lab Wash hands before eating	2				2	Student
Manual handling injuries	2	Use hoists for heavy beams If in doubt, get assistance for heavier lifting	2				2	Student
Laser damage to eyes	2	Observe instructions from technical staff to leave if required due to laser equipment usage	2				2	Student

Approved _____  _____

PRINT: _____ *Dr Jon Miles* _____

DATE: _____ 15/12/15 _____

REVIEW DATE: _____

Note: Risk Assessment to be completed in conjunction with Code of Practice

Risk assessment and safe scheme of work for field work

Title:

Physical Survey of the Mount Batten Breakwater from the survey vessels Dolphin.

Description:

This safe scheme of work relates to the deployment of oceanographic instrumentation from the vessel Dolphin. Equipment includes: a Valeport current meter for assessing flow dynamics and an echo sounder to be used to measure the depths of the sea bed. GPS will be used to obtain the vessel sampling locations. All equipment will be deployed from the survey vessel within Plymouth Sound. Equipment may be deployed over the side of the vessel either by hand or using an 'H' frame and winches for heavier items.

Hazards:

Heavy lifting, falls, electrical shock, cable interfering with vessel propeller

Risks:

Main risks are injury to person through exposure to electricity, lifting equipment, slips, trips and falls and Man over-board

Control Measures in Place:

1. Lifting will be shared between persons and supervised.
2. Person instructed to use hand rails and not overreach
3. Person will receive training on safe use and deployment of equipment
4. Person completing activities on deck of vessel will be provided with life jacket

The Safe System of Work:

1. The vessel skippers will discuss potential hazards and provide safety instructions and identify control measures in place.
2. Technical staff will check all electrical equipment is safe to use and restrict the use of non-waterproof equipment, e.g. logging units, to dry rooms on vessel.
3. Technical staff will be responsible for ensuring all equipment is deployed appropriately and students will be instructed in the safe use of all pieces of equipment.
4. The skippers will co-ordinate the winching and lowering of sensors and samplers from the vessel.
5. Students are not to switch on or use equipment until instructed how to do so safely.
6. Students and staff will wear life jackets at all time when on the deck of the vessel. In the cases when the rear deck doors are open, or when instructed to do so by the skippers, safety harnesses must be worn

General Risk Assessment Form
(Revised May 2014)

Date:	January 2016.	Assessed by:	Dr Jon Miles	Activity/Location	Physical Oceanographic fieldwork practicals in the Tamar Estuary conducted from survey vessels RV Falcon Spirit and RV Aquatay.
--------------	---------------	---------------------	--------------	--------------------------	---

Persons concerned: MAR514 students, MAR521 students, EOE3309 students, additional PU students, Dr Andrew Manning, Dr Luke Holmes, Mr William Davies, Mr David Uren, Mr Jonathan Coe, Antony Birchill (marine chemistry demonstrator), additional Plymouth University skippers, additional Plymouth University students, additional Plymouth University technical support, additional Plymouth University staff

Hazard	No. at Risk	Controls in Place at Present	L	M	H/E	Further Controls Necessary	Residual Risk Rating	Responsible Person(s)
Walking on marina pontoon walkway + lifting oceanographic sensors. Transferring persons from one vessel to another during the survey (Transfer persons & instrumentation to/from the vessels and to/from the minibuses).	All of the persons listed above numbers limited to capacity stated in vessels SOPs	Share lifting between persons. Use hand rails on vessels. Staff supervision and guidance on safe practice	2			Additional safety information will be provided by the vessel's skipper on the day.	2	Survey vessel Skippers, students and duty SoMSE technician
Electric shock (Use of mains / 12 volt electric supply on vessels).		Restrict electric logging units (non-waterproof types) to dry rooms on vessel. All mains electrical equipment to comply with University "COP Portable Appliance Testing"	2			Restrict electric logging units (non-waterproof types) to dry rooms on vessel.	2	Survey vessel Skippers, students and duty SoMSE technician
Cables interfering with vessel propellers (Winching / lowering sensors from the vessel to acquire		Make persons aware when sensor deployment is in progress. Staff Supervision	2			Skipper will co-ordinated these activities. If the CTD Rosette is to be deployed, the winch hydraulics will be	2	Survey vessel Skippers, students and duty

data).						operated by University staff and co-ordinated by the skippers.		SoMSE technician
Fall in water / trip / slip / fall on deck (General for the day on the vessel).		Ensure persons aware of potential hazards. Wear life jackets and use safety harnesses when required.	2			Additional safety will be provided by the Skipper	2	Survey vessel Skippers, students and duty SoMSE technician

Approved _____ *JRMiles* _____

PRINT: _____ *Dr Jon Miles* _____

DATE: _____ 08/01/16 _____

REVIEW DATE: _____

Note: Risk Assessment to be completed in conjunction with Code of Practice

APPENDIX D

Drawing for Falmouth model core

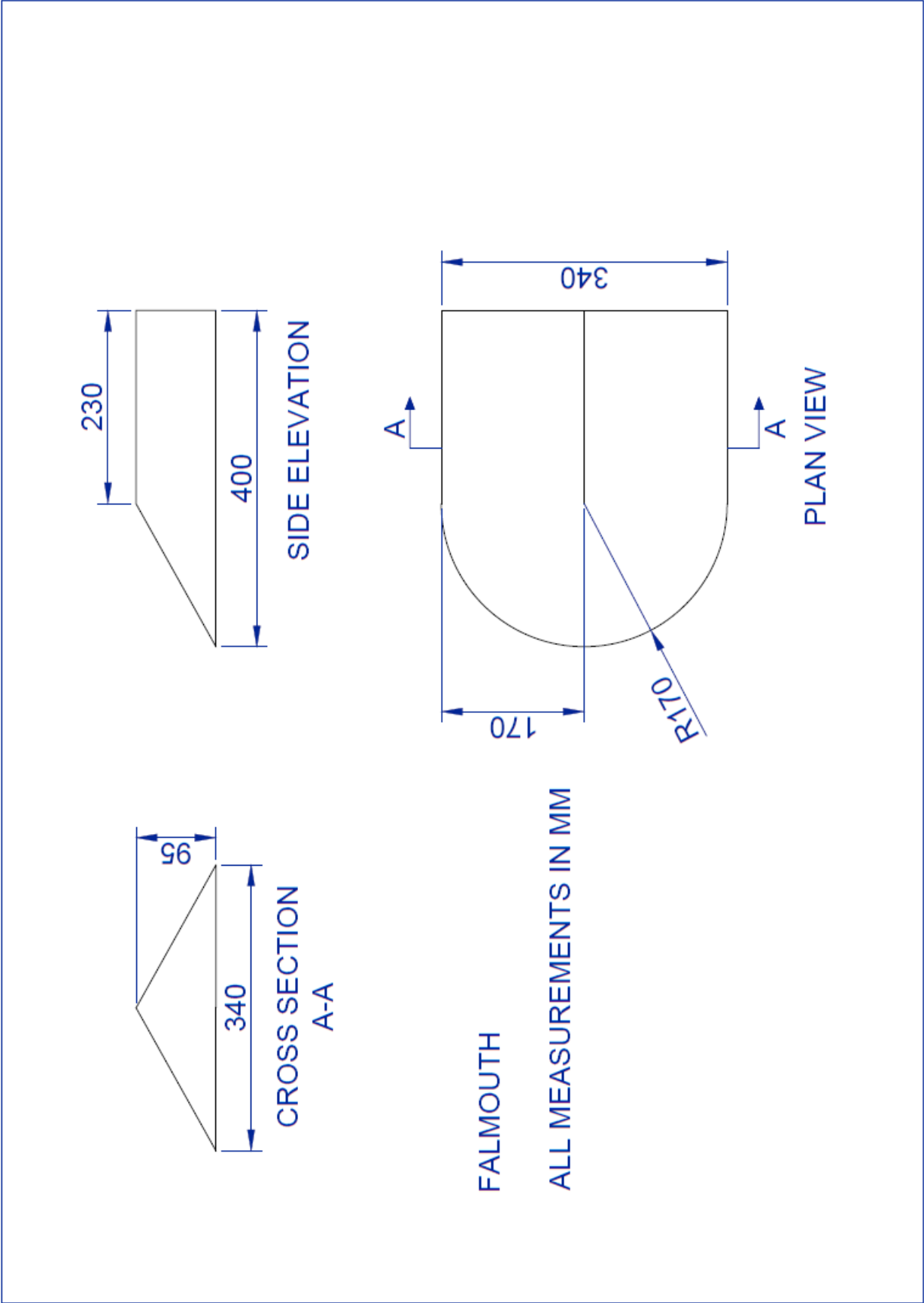

Drawing for Mount Batten model core

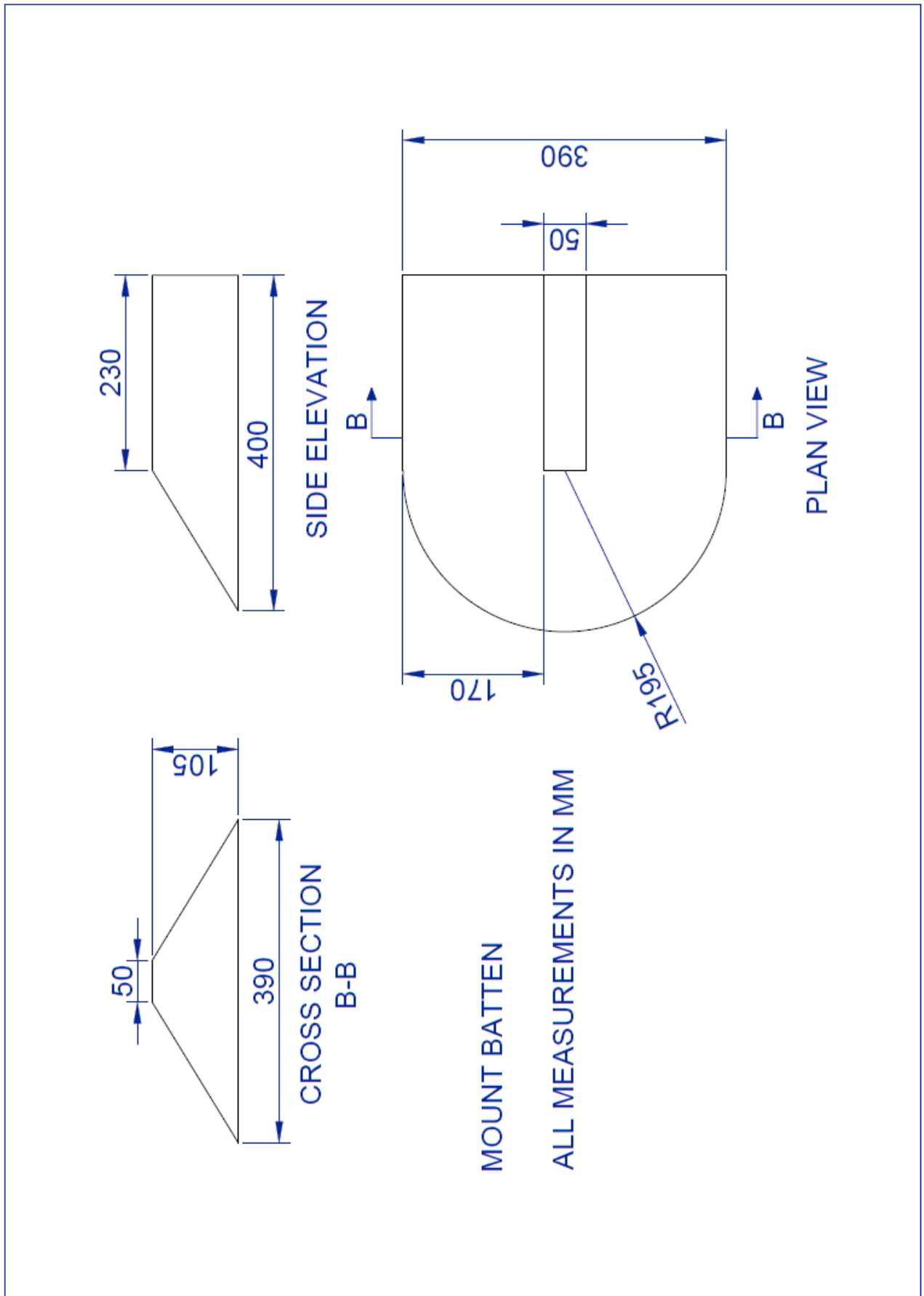

APPENDIX E

Example of Gantt chart used for project documenting progress up to January

Project progress at week beginning 14/12/15

