

2022

# Finite element analysis of a total wrist replacement: determining implant lifetime due to fatigue

Alton, E.

Alton, E. (2022) 'Finite element analysis of a total wrist replacement: determining implant lifetime due to fatigue', *The Plymouth Student Scientist*, 15(1), pp. 48-68.

<http://hdl.handle.net/10026.1/19458>

---

The Plymouth Student Scientist

University of Plymouth

---

*All content in PEARL is protected by copyright law. Author manuscripts are made available in accordance with publisher policies. Please cite only the published version using the details provided on the item record or document. In the absence of an open licence (e.g. Creative Commons), permissions for further reuse of content should be sought from the publisher or author.*

# **Finite element analysis of a total wrist replacement: determining implant lifetime due to fatigue**

Edward Alton

*Project Advisor: [Dr M Meng](#), School of Engineering, Computing, and Mathematics  
Faculty of Science and Engineering, University of Plymouth, Drake Circus, Plymouth,  
PL4 8AA.*

## **Abstract**

Total wrist replacement is a surgery in which an implant is used to help a patient regain a full range of painless movement in their wrist. However, there is little data to suggest the lifetime of implants when being used, implants should last as long as possible to reduce possible harm to patients and reduce the need of more surgery. This paper aims to use finite element analysis (FEA) to develop a model of a total wrist replacement and therefore develop a fatigue analysis based on the typical use of the implant. Results from the FEA were further corroborated using a rainflow count analysis. It was found that during the wrist movement cycles of radial-ulnar and flexion-extension the implant was suggested to have a lifetime of over 500 years when using loads up to 350N which is far beyond the expected use of the implant. Loads over 350N were suggested to be producing fatigue damage to the implant, with damage being focused at the extreme angles of the cycles. As a result, it is suggested that those with the implant should not lift large loads regularly, or regularly move to the extremes angles of movement, in order to reduce risk of damage to the component.

**Keywords:** FEA, Total Wrist Replacement, Fatigue, Simulation, Implant Lifetime

## **Introduction**

Total wrist replacement surgery is primarily used in patients with severe wrist arthritis, however, it is not commonly used due to the poor clinical success of the operation (NICE, 2008). The aim of the procedure is to give patients a range of movement that allows them to complete up to 80% of day-to-day tasks pain free (Handclinics, 2020). However, there is little data on its long term effects due to the small number of patients to study and insufficient evidence to support its efficacy in the long term (NICE, 2008).

As evidence for the long-term effects of the wrist implant is unavailable the lifetime of the implant needs to be tested. A finite element analysis (FEA) of the implant could allow a basis for the limits and lifetime of the implant to be calculated.

## **Aims and Objectives**

### **Aims**

What is the fatigue lifetime of the implant, and how is most likely to fail?

Could the design of the implant be improved to increase the lifetime or reduce chance of failure due to the results found in the FEA?

The aim of the paper is to analyse the forces on, and therefore fatigue of, a wrist implant to allow for more informed design improvements.

### **Objectives**

1. Conduct a literature review on the total wrist replacement implant options and review studies on the lifetime, design, materials, and advice on the use of the wrist and similar implants.
2. Review fatigue data for and biocompatibility of materials used in implant production.
3. Finalise and construct the geometry of the implant in SOLIDWORKS for the FEA analysis.
4. Conduct a FEA of the implant to try and find the limits of the design and its projected lifetime. Recording the effect of the forces using a fatigue analysis and the areas where failure is most likely.
5. Analysis of the fatigue data and locations most susceptible to failure.
6. Suggestions for design improvements based upon the data analysis.

## **Literature Review**

### **Medical usage of the total wrist replacement.**

The guidance published by the National Institute for Health and Clinical Excellence (NICE) details the procedure and its aims “to create a stable, pain free joint with a functional range of movement” (NICE, 2008). Due to the low number of these procedures completed, the source only offers minimal information surrounding the long-term effects of the procedure. The clinical success of the operation is reduced

compared with other joint replacements due to the complex movement in the wrist and complex surgery (Park & Lakes, 2007).

NICE cites studies of only 57 patients between 20 months and 4 years examining the wrist function and a study of 27 artificial wrist joint recipients found that four had unstable joints, this small sample may not be fully representative of the average lifetime of the joint. The Handclinics website also suggests that the total wrist replacement joints fail by loosening around 10 years after installation (Handclinics , 2020) agreeing with the NICE that the lifetime is limited due to the instability of the joint.

The main cause of implant failure besides infection of the wound is loosening (Park & Lakes, 2007). This is further reinforced by (Figgie, et al., 2014) analysis of the lifetime of a total elbow replacement. However, implants are being developed to be better attached to the bone through optimising osseointegration (attaching the implant directly to the bone) (Hoelwarth, et al., 2020) and therefore becoming less prone to loosening by improving fixation. As a result, joints may last longer and so a comprehensive understanding of the lifetime of the implant is required, this same reasoning is detailed in the life estimation of a knee joint prosthesis (Rawal, et al., 2016).

## **Current concern and challenges with the total wrist replacement**

### *Biocompatibility*

The wrist replacement must be biocompatible; it must be able to complete its function in the body in a “safe, reliable, economic, and physiologically acceptable manner” (Park & Lakes, 2007). It is argued that although biocompatibility is often viewed as a property of a material, any material could poorly influence a patient. Some materials are more likely to result in an acceptable biocompatible system (Williams, 2014). Thereby reducing the chance of wear leading to reduced ions in the blood.

### *Challenges with the use of the implant*

Implants can offer quality of life improvements for patients by increasing wrist movement and reducing pain, due to the removal and replacement of damaged tissue. However, wrist motion is never fully restored, and the use of the implant needs to be limited to simple not intensive or dangerous situations. Implants can be expected to last 10 to 15 years with careful use (American Academy of Orthopaedic Surgeons , 2013). The definition of ‘careful use of the implant’ could be better explained once finding the mechanical limits of the implant.

## **An analysis of wrist prosthesis and their geometry**

Wrist prostheses are made of two interlocking parts: the metacarpal implant which is connected to any of the 5 bones in the hand, and the radial implant which connects to the radius in the arm. These parts are connected using an articulation which offers

increased movement for the patient's wrist. All parts may be custom made or modular with different sized parts to allow for bespoke fitting. When considering the geometry of the implant it may be better to consider an average sized wrist as the basis for the CAD model.

The information published by Swemac in their MOTEC wrist joint prosthesis system sales brochure (Swemac, 2019) details their modular design consisting of different length threaded implants made of "titanium alloy coated with a resorbable calcium phosphate coating" the coating used to promote bone growth. The articulation section is made from "CoCrMo or carbon fibre reinforced PEEK". The design allows 80 degrees range of movement which decreases the chances of joint loosening. This source is a sales brochure so has a bias towards promoting the product, but it does provide evidence for its claims with references and scientific experiments. The Metal-on-Metal articulation is shown to provide a good range of function with high stability (Reigstad, 2014). The biomechanical test used in this source to test the movement of the MOTEC joint explains the range of movement available to patients after surgery "flexion-extension, radial-ulnar Deviation, and dart thrower motion" (Swemac, 2019). These could be used during the FEA analysis to know which directions force would be applied in day-to-day use.

The Motec prosthesis also has a surgical technique brochure, which aims to inform surgeons on the procedure to install the joint (Swemac, 2010). This would be more biased towards promoting the prosthesis as it is published by the manufacturer, it offers references to clinical articles when it discusses the wear of the materials against each other. The geometry of the prosthesis is also detailed in the brochure which may be useful in producing a CAD model of the prosthesis.

In examining other prostheses, it was discovered that the size of the implant is also considered as "the proper implant size is estimated preoperatively using x-ray templates" suggesting that to create the CAD model for research the size would have to be based on an average size wrist (Kinetikos Medical Inc, 2006). This source like the MOTEC implant does not offer any data on the lifecycle of the implants load bearing capacity, suggesting that "The patient is advised against impact loading of the wrist and repetitive forceful use of the hand." The ReMotion Total Wrist System, Operative Technique (Stryker, 2016) recommends "There is no clinical data to know the effect of sports activities on total wrist replacement patients" and "heavy lifting over 9kg is discouraged" This suggests that the proposed research should measure the limits of the wrist implant under use.

## **Materials:**

### *Metals*

Metals are used commonly in implants due to their high strengths and relatively high biocompatibility. However, metals may corrode in the body, causing weakening to the implants as well as damage to the patients' tissue through low grade inflammation. Metals commonly used in implants are titanium and its alloys

(Swemac, 2019) (Kinetikos Medical Inc, 2006), Cobalt Chrome (Kinetikos Medical Inc, 2006), and the CoCrMo alloy (Swemac, 2019) (Rawal, et al., 2016).

CoCrMo is used in metal-on-metal joints commonly since the 2000s in making artificial joints (Park & Lakes, 2007). In some patients performance can be excellent for over two decades, but in others it can fail after implication due to wear debris reacting with local tissue as shown by (Liao, et al., 2013) in their analysis of metal-on-metal hip replacements. It is also used in the Motec wrist prosthesis although their brochure claims high wear has not been identified in their prosthesis (Swemac, 2019) this is supported by (Reigstad, 2014) as modern articulations have low wear rates and long term clinical performance, due to the self-polishing effect. Fatigue of CoCrMo in implants can be enhanced by corrosion caused *in vivo* by surface notches being generated, this may be an issue for any implants with CoCrMo components (Lanzutti, et al., 2019).

Titanium is used in connections with bone due to its closer modulus of elasticity to bone (bone  $\approx$ 10-30 GPA, titanium alloys  $\approx$ 110GPA) than CoCrMo alloys ( $\approx$ 230GPA) (Reigstad, 2014). This high stiffness compared to bone could lead to bone atrophy as it is stress shielded by the implant. Titanium commonly used in implants is either pure titanium or an alloy, Ti6Al4V (Saenz de Viteri & Fuentes, 2013) (Park & Lakes, 2007). Titanium also offers superior biocompatibility, high corrosion resistance, and high capacity for osseointegration (Saenz de Viteri & Fuentes, 2013), making titanium a superior choice for the metacarpal and radial implants hence their frequent use (Swemac, 2019) (Stryker, 2016) (Kinetikos Medical Inc, 2006). If titanium is not coated or the surface is not modified the inactive oxide film on the titanium can be disrupted increasing the likelihood of failure of the implant due to corrosion (Saenz de Viteri & Fuentes, 2013).

### *Polymers*

Polymers are also used in prosthetic implants. Ultra-high molecular weight polyethylene (UHMWPE) is used in the Universal 2 implant (Kinetikos Medical Inc, 2006), and knee implants (Rawal, et al., 2016) for load bearing surfaces as metal-on-polyethylene articulation (Reigstad, 2014). UHMWPE is used due as there are no branches in the polymer, which increases the crystallinity to 60-70%; thereby improving the wear resistance of the polymer (Park & Lakes, 2007). Polymers are prone to fragmentation *in vivo* due to the cyclic loads on the load bearing surface. Wear can cause particles to be absorbed by the body resulting in inflammation and bone resorption, this is enhanced as third body particles could gain access to the articulation increasing wear (Rokkum & Reigstad, 1998) (Green, et al., 1998) (Figgie, et al., 2014). This can be reduced using cross-linked UHMWPE as wear is reduced but smaller particles are produced which may accelerate destruction of bone tissue (Kuzyk, et al., 2011). The wear from metal-on-polyethylene articulation is higher than the wear from the CoCrMo metal-on-metal articulation (Reigstad, 2014) suggesting that metal-on-metal is the more biocompatible option for joint articulation.

### *Composites*

For a composite to be biocompatible, each constituent needs to be biocompatible especially the interface between then constituents as if this is degraded it may lead

to the composite becoming damaged (Park & Lakes, 2007). Composites may be better suited to use when being attached to bone in the metacarpal and radial implants as they can be made to have a stiffness similar to bone helping to reduce bone atrophy (Park & Lakes, 2007). The matrix material should also be considered, if it has a tendency to absorb water, once *in vivo* this could cause a reduction in stiffness of the composite (Park & Lakes, 2007).

Composites can be used to decrease the wear rate of polymers in the articulation section. UHMWPE could be mixed with carbon nano filler to decrease its wear rate, however the biocompatibility of this has been untested so would be unsuitable to model this as an example (Yousef, et al., 2017). Glass fibre reinforced composite (GFRC) may be a more suitable option than titanium for the radial and metacarpal implants due the elastic modulus of GFRC (15-20GPA) being closer to bone (10-30GPA) thereby reducing chances of bone atrophy (Chan, et al., 2018). GFRC is worth considering in the model due to its high tensile strength and enhanced osseointegration when a biofibre structure and bioactive glass is used (Chan, et al., 2018). Further clinical trials may be needed to fully understand the long-term effect on the patient when GFRC is used.

### **Similar Papers on the mechanical lifetime of implants**

A similar paper examining the fatigue on a knee joint replacement (Rawal, et al., 2016) uses a CAD model to replicate the prosthesis and ANSYS to complete an FEA analysis. The article considers the lifetime of the patient and whether the patient is likely to outlive the part and need further invasive surgery as well as defining the lifespan of the prosthesis as “proper functioning of its intended function within prescribed load limit and environmental condition without causing any kind of pain for a particular interval of time”. Both the definition of a lifetime of a prosthesis and whether the age of patients should be considered should be defined in this paper as they have been in the article.

A wrist prosthesis wear characterisation also like that completed in the experiment published in the 2003 bioengineering conference in Florida (Chen, et al., 2003) may need to be completed to determine the real-world lifetime of the implant outside of simulations. This experiment helps to examine the lifetime of an implant due to wear but also provides the equivalent of 1 million cycles being equivalent to one year of use and uses radial-ulnar, and flexion-extension cycles as being representative of day-to-day use of a wrist joint.

### **Wrist cycles**

Similar papers examining the lifetime of an implant model the cycles in which the implant go through and use those as the basis for the fatigue simulation, this is shown in the fatigue simulation of a hip implant by Yeoman (Yeoman, et al., 2012). In this simulation a cycle is demonstrated by changing the direction and magnitude of loading, this could be used to demonstrate a cycle in this paper. Cycles of the wrist are more complex than those of the hips although wrist movement has been

measured using frozen cadavers: Hooke examines the range of movement a cadaver can make in radial-ulnar and flexion-extension with a total wrist replacement implanted (Hooke, et al., 2015). A similar investigation by Shah used a physiologic wrist simulator to measure the angles of movement of a wrist during cycles (Shah, et al., 2017). Werner examined the forces on the wrist during a general cycle in flexion-extension and radial-ulnar (Werner, et al., 2010), these cycles could be used to demonstrate the movement of a wrist and so should be applicable to this paper.

### **Fatigue calculations**

Fatigue life of a model is calculated dependent on loading condition, fatigue life, temperature, and given material type (Kaolczuk, et al., 2020). Three main methods are used to calculate fatigue life in a part: total life, crack initiation and crack growth (Design News, 2001).

Total life calculations are the process in which an analysis of cycles, such as a rainflow analysis, is used to calculate the local stress time history. The loading in the cycles is then assessed against the SN curve for the material and the cycles are linearly added using Miner's rule. Extensive use is made of Miner's equation or a modified Miner's equation specific to the situation in which it is used. Miner's rule is shown below:

$$C = \sum_{i=1}^k \frac{n_i}{N_i}$$

Alternatively, the fatigue life can be calculated using crack initiation analysis to locate where a crack is likely to start. Cyclic stress-strain modelling and an elastic-plastic correction such as the Neuber rule (shown below) can be used to calculate the fatigue life of a part. It is possible to use FEA and then perform elastic-plastic or linear rule corrections afterwards, however the results from this method can be unpredictable as the linear and elastic-plastic corrections give varying results (Samuelsson, 2008).

$$\sigma = \frac{K}{\varepsilon}$$

The Crack growth analysis method uses linear elastic fracture mechanics to calculate the crack growth of pre-cracked structures such as welds. As a result, this method is not applicable to the implants in this study. The total life method of calculating the force is the most applicable to the materials and loading conditions of the implant.



## FEA Model Set Up

### Modelling the Prosthesis

A Solidworks 2020/21 model based upon the geometry of the MOTEC prosthesis was constructed, shown in Figures 1 and 2. It was based on the MOTEC prosthesis due to this being the most developed design, which gives the patient the most degrees of movement, and has high biocompatibility. As the implant is available in a range of sizes, to find the best fit for patients, the model was made using the median sizes of components. This should have limited effect on the results as geometry is the same for all sizes.

Solidworks was used as it allows a model to be created using a range of materials already in its library and for separate parts to be modelled and then assembled. The model was made of Ti6Al4V for the metacarpal and radial components, this material was already found in the Solidworks material library. CoCrMo is the material for the articulation components, this material was not in the Solidworks library so was added based upon material properties from CES Edupack 2020, and the SN curve sourced from a life estimation of a hip joint prosthesis (Desai, et al., 2014). These were then used to make separate assemblies of the metacarpal and radial parts of the prosthesis therefore the model should be suitably representative of the implant to perform an FEA.

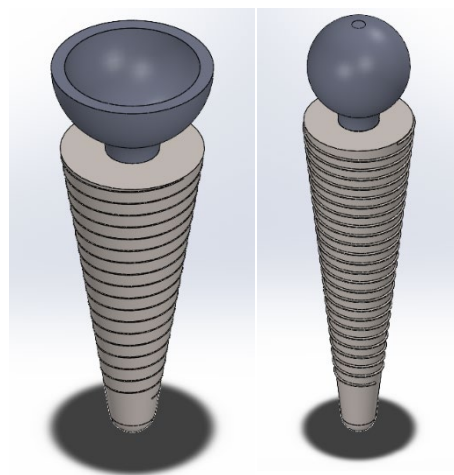

Figure 1: Radial Component

Figure 2: Metacarpal Component

### Static Failure Simulation:

Static failure is when the design fails due to a constant load below the fracture stress. These simulations are required to show the direction and magnitude of the force upon which the fatigue simulations would be based. In each static simulation the titanium sections of the component were simulated as being fixed to the bone and forces applied to the metacarpal and radial CoCrMo components at interval angles of the radial-ulnar and flexion-extension movements. The maximum angle which the force can be directed is found to be 10° each way in the radial-ulnar direction, and 30° in the flexion-extension direction (Shah, et al., 2017).

The intervals between angles were 2 degrees for the radial-ulnar cycle from 0 to 10 degrees, and 10 degrees for the flexion extension cycle from 0 to 30 degrees. As the implant is symmetrical in 360 degrees results should be equal for negative and positive angles, as a result simulation of negative angles were not needed. This method has its limitations as it does not account for each point in the cycle, only the intervals which are being assessed.

## Fatigue Failure Simulations

Fatigue failure (when the design fails due to the repeated load below the fracture stress) form microcracks where the stress concentrates; as more cycles are completed the cracks grow and propagate leading to fractures forming and ultimately failure of the part (Park & Lakes, 2007). Fatigue theory is not fully understood so attempts to predict the fatigue failure of a product may have high uncertainty (Kyte, 2020).

The fatigue of a material can be displayed on a S-N curve, plotting the fatigue strength of a specimen against the number of stress cycles completed (Kyte, 2020). Some materials have an endurance limit, in which they can have a “infinite life” meaning they can survive an infinite number of cycles below the endurance limit load. Ti6Al4V, the material used in the metacarpal and radial bone implants, has an estimated endurance limit of 620MPa (Akai, et al., 2017). While CoCrMo, the material used for the articulation components, has an estimated endurance limit of around 200MPa (Desai, et al., 2014).

FEA fatigue analyses were completed on the model to find the point that failure is most likely to occur at. The fatigue simulations were run using variable amplitude loading cycles depending on its movement in radial-ulnar and flexion extension, these force cycles were found from (Werner, et al., 2010). These cycles were used as they suggest how day to day basic wrist movement would affect the lifetime of the implant. Dart throwing and circumduction motion cycles were not used in the simulation as they are amalgamations of the flexion-extension and radial-ulnar cycles. The cycles shown above were normalised using standard score normalisation (Alam, 2020) to not distort the results by increasing the amplitude of the stresses used in the simulation.

## Fatigue Hand Calculations

Rainflow analyses in conjunction with Miner’s rule, shown below, were also completed on the flexion-extension and radial-ulnar cycles to corroborate the results from the FEA.

$$C = \sum_{i=1}^k \frac{n_i}{N_i}$$

A rainfall analysis was used to simplify the variable amplitude radial-ulnar and flexion-extension cycles. These simplified cycles were then used in Miner’s rule to calculate the total number of cycles before failure at that loading. These results were compared to the FEA fatigue results to corroborate the validity of the study.

The results from the fatigue simulations were plotted at intervals of the angles in the cycles. This allowed the minimum fatigue of each angle at a specific loading to be recorded. The minimum number of cycles which the part survived across all angles was taken to be the lifetime of the implant at that loading.

## Results and Discussion

### Rainflow Cycle Counting Analysis and Miner's Rule

A rain flow analysis of the normalised cycles was completed to allow for hand calculations to corroborate the results of the simulation. Diagrams are shown in Figures 3 and 4, results are shown in Tables 1 and 2.

**Table 1:** Simplified Flexion Extension Cycle

Flexion Extension Cycle	
Loading (N)	No. of cycles
1.93	0.5
1.27	1
0.77	0.5
2.7	0.5

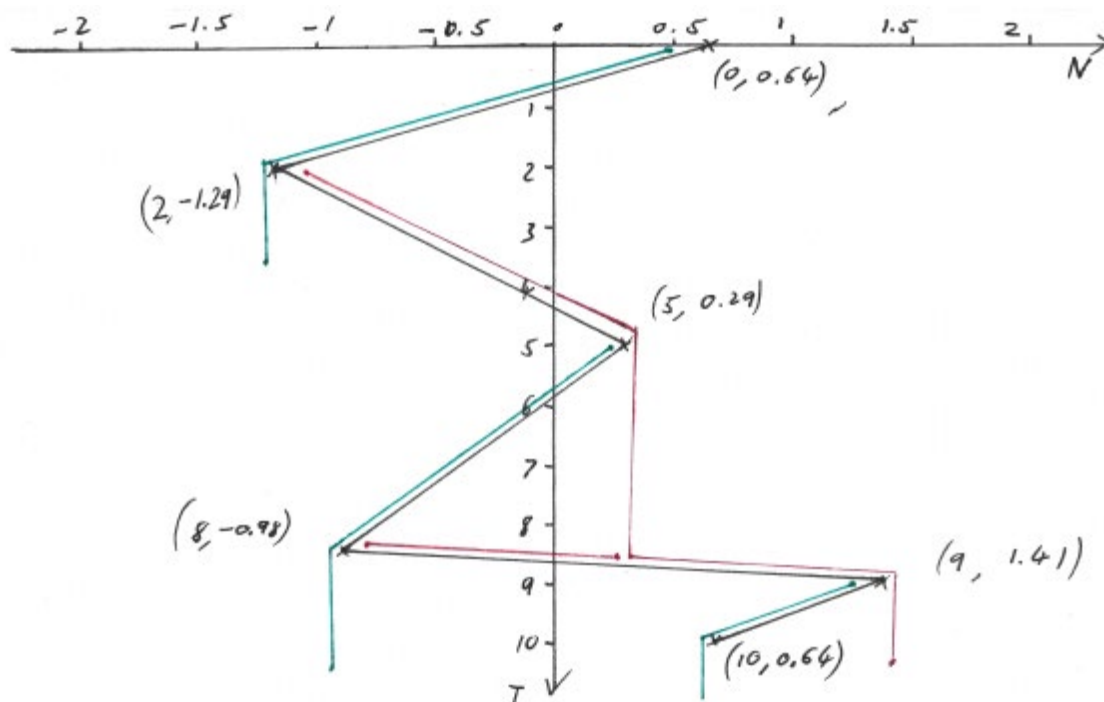

**Figure 3:** Flexion Extension Rainflow Diagram

**Table 2:** Simplified Radial Ulnar Cycle

Radial Ulnar Cycle	
Loading (N)	No. of cycles
2.03	0.5
1.91	0.5
1.79	0.5
0.96	0.5
0.83	0.5
0.48	0.5
0.24	0.5
0.12	0.5

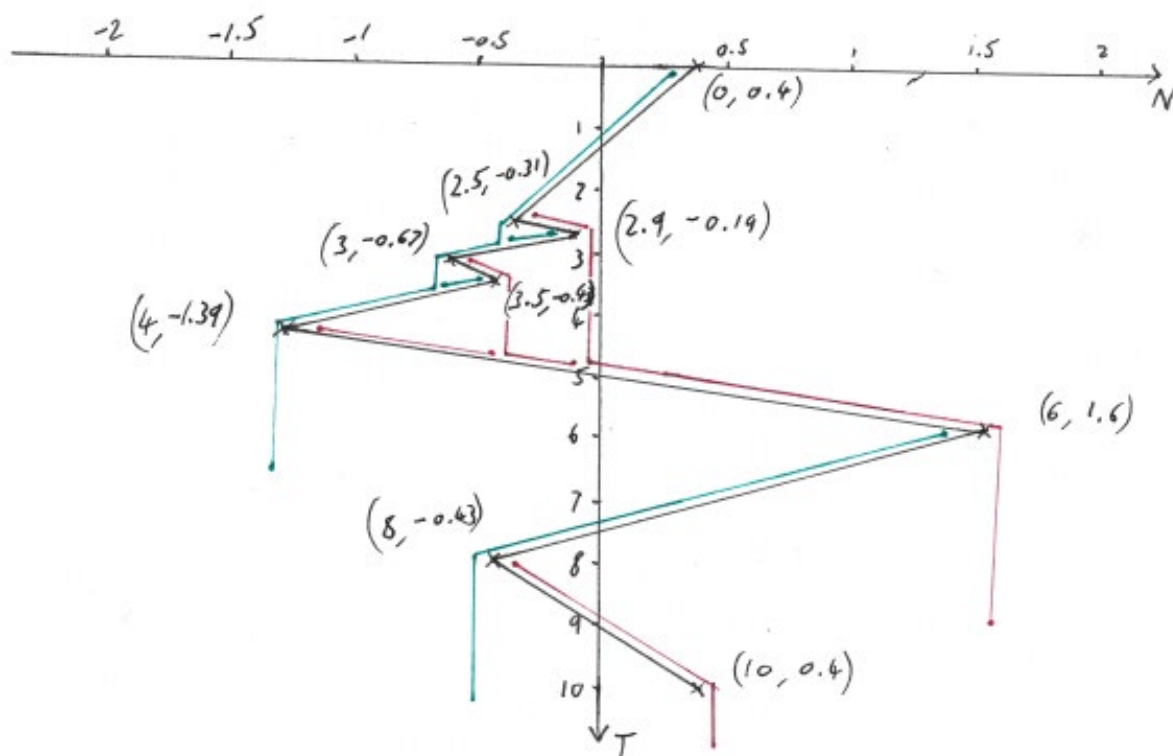

**Figure 4:** Radial Ulnar Rainflow Diagram

These suggest that the loading of the cycles is small when acting on the wrist in the normal loading conditions of these cycles, peaking at 2.03N for only half a cycle in the radial-ulnar analysis. Due to these being low load cycles they fall below the endurance limit of both CoCrMo and Ti6Al4V which theoretically leads to an infinite lifetime of the implant. Although this is unlikely as loading will change and wear will still occur leading to the failure of the part. These Rainflow analyses, whose results are shown in Table 3, can be taken as being representative of the implant going through normal movement of the wrist without extra loading, a real-world equivalent would be moving the wrist without carrying anything.

**Table 3:** Rainfall Cycle analysis at 75N Initial Loading

Load (N)	Cycles	Stress (Pa)	MPa
1930	0.50	1.49E+08	178.92
1270	1.00	9.80E+07	97.99
770	0.50	5.94E+07	59.41
2700	0.50	2.08E+08	208.33

Miner's rule is applicable when the loading in a cycle is above the endurance limit of the material, in this case when the stress on the implant is above 200MPa. The point at which a cycle reaches 200MPa was found using Excel's solver function when the initial loading was equal to 960N, this suggests that 960N is the maximum loading the implant can withstand before fatigue failure develops.

The lifetime of the implant at 1000N loading was calculated using the simplified cycles from the rainfall analysis and Miner's rule. This loading only provided stresses above 200MPa in the Flexion extension cycle for half a cycle, shown in Table 3. Using Miner's rule and the SN curve for CoCrMo (Desai, et al., 2014), the lifetime of the implant was found to be 200 million cycles or an equivalent of 200 years use (Table 4).

However, this method of calculating fatigue may not be that accurate as it only considers the fatigue strength of the material and the stresses of the cycle it undergoes. The implants' geometry, direction of force, and overall situation when under loading are not considered by the equation, which may have a large impact on how and where fatigue is likely to occur. The equation also does not consider the probability involved in fatigue damage nor the load sequence in the cycle, both of which can affect the fatigue damage in the part (Sun, et al., 2014). This suggests that the results obtained from this equation have high levels of uncertainty but provide a general estimation of lifetime for the material when put under the stresses of the cycle.

**Table 4:** Miner's Rule at 1000N Loading

Miner's Rule at 1000N Loading				
Stress (MPa)	Number of Cycles – $N_i$	Number of Cycles – $n_i$	Damage to Implant - C	Number of Cycles Until Damage = 1
208.33	1.00E+08	0.5	5.00E-09	2.00E+08

### Static Simulation results

The static simulations calculate the equivalent von Mises stresses at certain loadings, used as the basis of the fatigue simulations. The static studies were used to find the failure point of the implant when put under high loading. A loading of 850N was used as the maximum loading as it is equal to the loading of supporting the average man's weight by the wrist. While this situation is unlikely to occur, this should be used as an extreme loading condition the implant should survive. Maximum stresses shown (Table 5) have a minimum factor of safety of 2.9, this should be an acceptable factor of safety for the stresses due to loading that extreme being unlikely.

**Table 5:** Stresses due to 850N Loading

Angle	Metacarpal Stress (MPa)	Radial Stress (MPa)
Flexion-Extension		
0	210.00	200.00
10	210.00	230.00
20	190.00	250.00
30	240.00	340.00
Radial-Ulnar		
0	210.00	200.00
2	200.00	220.00
4	230.00	220.00
6	198.00	210.00
8	200.00	200.00
10	210.00	230.00

## Fatigue Simulation Results

The minimum number of cycles were recorded against the angle of direction of the force and the maximum magnitude of the von Mises stress in the static simulation. Results in Table 6 and 7 show a normal loading cycle at 1N and in Table 8 for a higher loading at 425N. Full results are shown in the appendix. These provide estimations of the cycles effect on the implant and the lifespan of the implant under normal movement cycle conditions therefore giving an estimation of how many equivalent years the part can be used when going through the radial-ulnar and flexion-extension cycles.

The results from both radial and metacarpal simulations following the radial-ulnar and flexion-extension cycles suggest that the implant has a lifetime of a minimum of 500 million cycles. The fatigue damage of these cycles could be seen as equivalent as the fatigue damage caused by the movement of the wrist while with no load. This suggests the implant having an infinite lifetime as it would be equivalent to 500 years of use, far beyond the expected time a patient could use the implant. These results could be seen as reliable as they are similar to results of hand calculations.

As the loading was increased to 350N fatigue damage started to occur in the FEA whereas using hand calculations it was found that fatigue damage started at 960N. The difference of 610N could be attributed to uncertainty in Miner’s rule, which does not consider the geometry of the implant and how stresses are focused. As geometry considered in FEA these results could be more reliable.

Further results with a higher loading of 425N (Table 8), which could be comparable to a patient supporting half the average man’s weight on one wrist. This situation is unlikely and should be considered an extreme upper boundary of what is to be expected by the wrist.

**Table 6:** Flexion Extension Cycle 1N Loading

<b>Flexion Extension cycle</b>				
<b>Angle</b>	<b>Radial</b>		<b>Metacarpal</b>	
	<b>Maximum Stress (MPa)</b>	<b>Minimum Years of Use</b>	<b>Maximum Stress (MPa)</b>	<b>Minimum Years of Use</b>
0	0.230	50000	0.250	5000
10	0.275	500	0.246	500
20	0.271	500	0.225	500
30	0.371	500	0.260	500

**Table 7:** Radial Ulnar Cycle 1N Loading

Radial Ulnar cycle				
Angle	Radial		Metacarpal	
	Maximum Stress (MPa)	Minimum Years of Use	Maximum Stress (MPa)	Minimum Years of Use
0	0.230	50000	0.250	50000
2	0.249	500	0.242	500
4	0.263	500	0.270	500
6	0.252	500	0.233	500
8	0.240	500	0.234	500
10	0.275	500	0.246	500

**Table 8:** FEA results at 425N Loading.

Flexion Extension cycle				
Angle	Radial		Metacarpal	
	Maximum Stress (MPa)	Minimum years of use	Maximum Stress (MPa)	Minimum years of use
0	97.87	50000.00	106.19	50000.00
10	116.70	500.00	104.57	500.00
20	126.69	500.00	96.28	500.00
30	170.87	11.21	119.70	500.00

The results for the radial-ulnar cycle are not presented, as the minimum years of use was found to be 500 years, suggesting an infinite lifetime for the implant. The flexion-extension results suggest that under loading of 425N the implant has a minimum fatigue lifetime of 11.21 years, suggestive of a reasonable lifetime for the implant as this loading would be a rare occurrence in day-to-day use. These results are suggestive of Miner’s rule not considering the geometry of the part, especially as shown by Figure 5 the failure occurs at the point in the stem where force is applied as stresses are concentrated there.



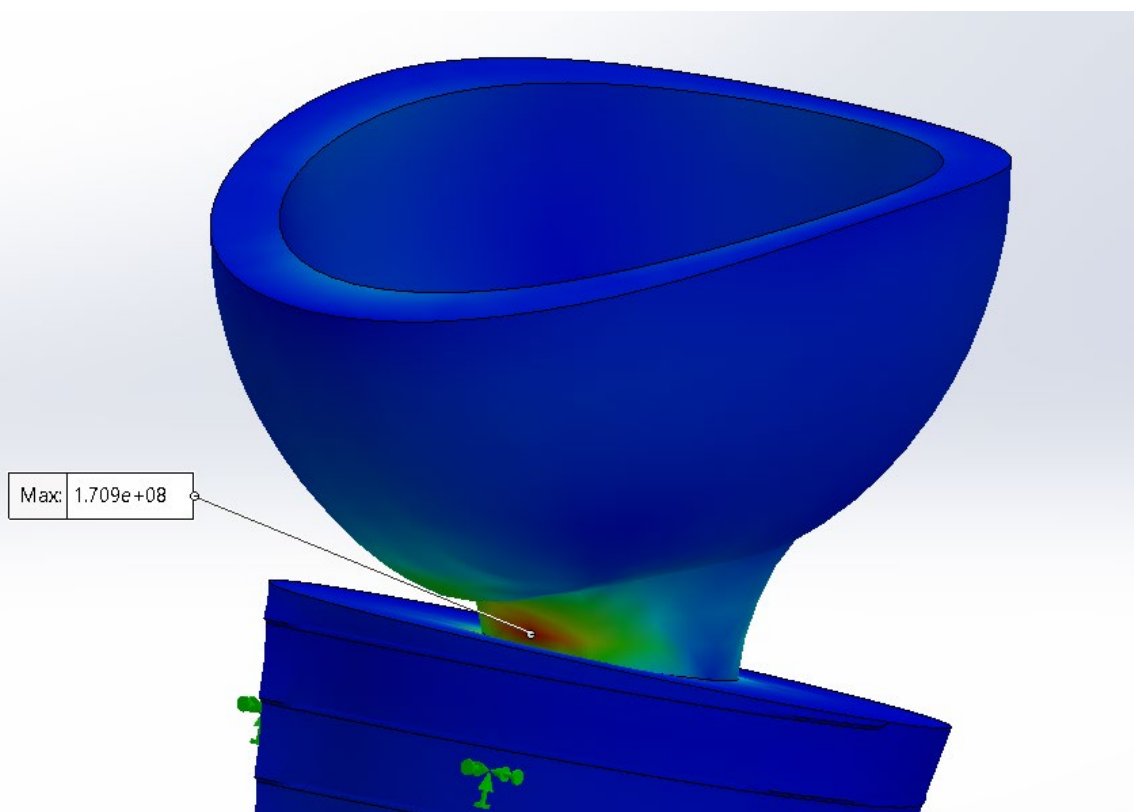

**Figure 5:** Stress Concentration at 425N Loading

The results found suggest that the implant is susceptible to fatigue when following the radial-ulnar and flexion-extension cycles at loads above 350N. At higher angles of direction for the force there is higher fatigue damage to the side of the articulation components. This fatigue data suggests that weights above 35kg should not be carried regularly by a person with the implant as the load from doing such and moving the wrist would cause fatigue damage to the part. The data also suggests that the most damage to the implant occurs at the extremes of the angles of cycles, suggesting that bending the wrist while carrying a load should be avoided to increase the lifetime of the implant.

The results also suggest that most of the fatigue occurs where the force acts through the CoCrMo articulation components, although when the force acts in a high angle the damage to the part is centred at the edge of the ball and socket on the connecting stem to the bone implants. This correlates with real-world issues causing the failure of the part where the implant has wear at the articulated joint. These parts may be able to have a higher fatigue life if another material was used which is harder and stronger. Possible materials could be composites that could be designed for articulating joints or nano materials could be used as a material coating; however new materials would need to be tested for biocompatibility as wear could lead to serious health issues if nanoparticles are released into the body at a high concentration. To reduce failure at high angles of movement the stems of the articulation components could be made thicker although this could reduce the movement of the wrist of patients.

## Conclusion and Recommendations

These simulations are unlikely to be indicative of how the implant acts *in vivo*. This may be due to the force acting on the wrist being more displaced across the wrist through tendons, bone, and muscle rather than acting completely through the implant as was modelled. For a simulation to be more accurate it may be better to simulate the implant *in vivo* as to show the full direction of forces through the entire wrist structure. Due to fatigue simulations being more prone to giving unreliable results, experiments should also be considered that investigate the real-world fatigue life of the implants using samples in a fatigue test rig such as that used in a wear characterization of a total wrist replacement prosthesis (Chen, et al., 2003).

This simulation does not model the real-world movements of a wrist well and so may not be useful in its aim of finding the lifetime of the implant in day-to-day use due to the wrist having many degrees of movement with a variety of loading conditions. To model the wrist using an average cycle would be impossible as there is no such thing as a normal loading cycle for a wrist compared with those used when modelling the hip which relies on one action, that of walking. Wrist movements are an amalgamation of flexion-extension and radial-ulnar cycles so they could be seen as a best estimation for the lifetime of the implant when using FEA simulations, despite being unlikely to occur often in a real-life situation.

Accuracy in simulation results is lost as it does not fully model a cycle of the wrist. In a cycle the application of the load should be able to move fluidly around the wrist making one cycle, from which a fatigue damage calculation can be produced. This is not an option with Solidworks, so fatigue simulations were completed at interval angles for a cycle, and the results at that loading assumed to be the minimum fatigue of that loading for the cycle. Using this method means that to find the fatigue data for a specific loading requires 20 different static and fatigue simulations, this makes collecting data to find the fatigue limit of the implant challenging.

For a more accurate simulation using the same basis of investigation a simulation in which the implant is modelled *in vivo* and in which a cycle can be fully modelled with changing amplitude and location of the loading occurring in one simulation. This would allow for more simulations to be run giving more accurate results. However, if this investigation were to be completed it would be very general and may only be a basis for determining the lifetime of the implant, other experiments would need to be completed to determine the actual fatigue life of the implant. Many factors affect the fatigue strength and failure of the implant such as: biocompatibility; debris causing damage to the implant especially the articulating components, issues during manufacture or with the base materials; human error with use, or other modes of failure such as implant loosening. The fatigue life of the implant, although suggested by this research to be over 500 years with careful use, would only be able to be determined by using real world experiments and data samples from patients to get truly encompassing results. The theoretical fatigue lifetime of the implant is unlikely to be the same as the lifetime of the implant in use, as wear, loosening, and infection are also large modes of failure for the prosthesis.

This research has set down a basis for what the lifetime of the implant may be, but further experimentation should be completed to examine the lifetime *in vitro* and *vivo* due to the limitations of methodologies used especially noting the differences between FEA and Miner's rule calculations. To find the true lifetime of the implant all consideration should be made to the complex motions and uses of the wrist.

## **Nomenclature**

C - Damage Total (where 1 = failure)

CAD – Computer Aided Design

FEA – Finite Element Analysis

GFRC – Glass Fibre Reinforced Composite

K - constant

NICE – National Institute of Clinical Excellence

N<sub>i</sub> – Number of cycles the material can survive, from SN curve

N<sub>i</sub> – Number of cycles at given amplitude

UHMWPE – Ultra-high molecular weight polyethylene

k - Number of different amplitudes

ε - Strain

σ – Stress N/m<sup>2</sup>

## **Acknowledgements**

I would like to thank Dr Meng for his invaluable help and direction in the course of this paper. Dr Besinis for his thorough marking and feedback in the interim report. Adam Kyte for his work in making this module run smoothly and informative support material. My housemates for their long suffering with living with me 24/7 through this pandemic and Jan Grybos for motivating me through this work.

## **References**

Akai, A., Shiozawa, D. & Sakagami, T., 2017. Fatigue limit estimation of titanium alloy Ti-6Al-4V with infrared thermography. *Thermosense: Thermal Applications*, Volume 10214.

Alam, R., 2020. *Normalization vs Standardization Explained*. [Online] Available at: <https://towardsdatascience.com/normalization-vs-standardization-explained-209e84d0f81e> [Accessed 03 05 2021].

American Academy of Orthopaedic Surgeons , 2013. *OrthoInfo*. [Online]  
Available at: <https://orthoinfo.aaos.org/en/treatment/wrist-joint-replacement-wrist-arthroplasty/>  
[Accessed 27 11 2020].

Bajuri, M., Kadir, M. R. A., Murali , M. R. & Kamarul, T., 2013. Biomechanical analysis of the wrist arthroplasty in rheumatoid arthritis: a finite element analysis. *Medical and Biological Engineering and Computing* , Volume 51, pp. 175-186.

Chan, Y.-H. et al., 2018. An evaluation of the biocompatibility and osseointegration of novel glass fiber reinforced composite implants: In vitro and in vivo studies. *Dental Materials* , 34(3), pp. 470-485.

Chen, Q. et al., 2003. *Wear Characterization of A Total Wrist Replacement Prosthesis*. Sonesta Beach, Summer Bioengineering Conference.

Desai, C., Hirani, H. & Chawla, A., 2014. Life Estimation of Hip Joint Prosthesis. *Journal of The Institution of Engineers (India)* , 96(3).

Design News, 2001. *How to Predict Fatigue Life*. [Online]  
Available at: <https://www.designnews.com/materials-assembly/how-predict-fatigue-life>  
[Accessed 30 04 2021].

Figgie, M. P., Wright, T. M. & Drinkwater, D., 2014. What Design and Material Factors Impact the Wear and Corrosion Performance in Total Elbow Arthroplasties?. *Clinical Orthopaedics and Related Research*, 472(12), pp. 3770-3776.

Green, T. et al., 1998. Polyethylene particles of a 'critical size' are necessary for the induction of cytokines by macrophages in vitro. *Biomaterials*, 19(24), pp. 2297-2302.

Handclinics , 2020. *Wrist Replacement*. [Online]  
Available at: <https://www.handclinics.co.uk/hand-conditions/wrist-replacement/>  
[Accessed Oct 2020].

Hoelwarth, J. S. et al., 2020. Osseointegration for Amputees. *JBJS Reviews*, March, 8(3), p. 43.

Hooke, A. et al., 2015. An Anatomic and Kinematic Analysis of a New Total Wrist Arthroplasty Design. *Journal of Wrist Surgery* , 4(2), pp. 121-127.

Jin-Xing, M. & Yong-Qing Xu, 2015. The instability of wrist joint and total wrist replacement. *Chinese Journal of Traumatology*, 17 Dec, pp. 49-51.

Kaolczuk, A., Papuga, J. & Palin-Luc, T., 2020. Progress in fatigue life calculation by implementing life-dependent material parameters in multiaxial fatigue criteria. *International Journal of Fatigue*, Volume 134, pp. 1-13.

Kinetikos Medical Inc, 2006. *Universal 2 Total Wrist Implant System surgical technique*. PlainsBoro: Integra LifeSciences Corporation .

Kuzyk, P. et al., 2011. Cross-linked versus conventional polyethylene for total hip replacement. *The Journal of Bone and Joint Surgery* , 93-B(5).

Kyte, A., 2020. *Stress Concentrations and Fatigue*. Plymouth : Plymouth University .

Lanzutti, A. et al., 2019. Corrosion fatigue failure of a high carbon CoCrMo modular hip prosthesis: Failure analysis and electrochemical study. *Engineering Failure Analysis*, Volume 105, pp. 856-868.

Liao, Y. et al., 2013. CoCrMo Metal-on-Metal Hip Replacements. *Physical Chemistry Chemical Physics* , 15(3), pp. 746-756.

National Institute for Health and Clinical Excellence, 2008. *Treating wrist arthritis by implanting an artificial wrist*. [Online]

Available at: <https://www.nice.org.uk/guidance/ipg271/resources/wrist-joint-replacement-pdf-310833901>

[Accessed 10 2020].

Park, J. & Lakes, R., 2007. *Biomaterials, An introduction*. 3rd ed. New York: Springer .

Rawal, B., Yadav, A. & Pare, V., 2016. Life Estimation of Knee Joint Prosthesis by Combined Effect of Fatigue and Wear. *Procedia Technology*, 1(23), pp. 60-67.

Reigstad, O., 2014. Wrist arthroplasty, Bone fixation, clinical development and mid to long term results. *Acta Orthopaedica*, 85(354), pp. 1-53.

Riegstad, O. et al., 2012. Promising one- to six-year results with the Motec wrist arthroplasty in patients with post-traumatic osteoarthritis. *The Journal of Bone and Joint Surgery*, 94-Bg(11), pp. 1540 - 1545.

Rokkum, M. & Reigstad, A., 1998. Polyethylene wear with an entirely HA-coated total hip replacement 79 hips followed for 5 years. *Acta Orthopaedica Scandinavica*, 69(3), pp. 253-258.

Saenz de Viteri, V. & Fuentes, E., 2013. Titanium and Titanium Alloys as Biomaterials . In: J. Gegner, ed. *Tribology, Fundamentals and Advancements* . London: IntechOpen.

Samuelsson, L., 2008. Fatigue Analysis: The Super-Neuber Technique for Correction of Linear Elastic FE Results.. Anchorage, 26TH INTERNATIONAL CONGRESS OF THE AERONAUTICAL SCIENCES.

Shah, D. et al., 2017. The effects of wrist motion and hand orientation on muscle forces: A physiologic wrist simulator study. *Journal of Biomechanics*, Volume 60, pp. 232-237.

Stryker, 2016. *The ReMotion Total Wrist System Operative Technique*. Bohnackerweg: Stryker.

Sun, Q., Dui, H.-N. & Fan, X.-L., 2014. A statistically consistent fatigue damage model based on Miner's rule. *International Journal of Fatigue*, Volume 69, pp. 16-21.

Swemac, 2010. *Motec Wrist Joint Prosthesis Surgical Brochure*. [Online] Available at: <https://www.medopt.com.au/images/Documents/motec-wrist->

[replacement-brochure.pdf](#)

[Accessed 11 11 2020].

Swemac, 2019. Motec Wrist Joint Prosthesis System Sales Brochure. Linköping: Swemac.

Werner, F., Short, W., Palmer, A. & Sutton, L., 2010. Wrist Tendon Forces During Different Dynamic Wrist Motions. *The Journal of Hand Surgery*, 35(4), pp. 628-632.

Williams, D. F., 2014. There is no such thing as a biocompatible material. *Biomaterials*, 35(38), pp. 10009-10014.

Yeoman, M., Cizinauskas, A. & Rangaswamy, D., 2012. *Fretting Fatigue in Modular Orthopaedic Implants*. Milan, Continuum Blue.

Yousef, S. et al., 2017. Wear behaviour of UHMWPE reinforced by carbon fibre nanofiller and paraffin oil for joint replacement. *Materials Science and Engineering: C*, Volume 73, pp. 234-244.

**Appendices are provided separately as supplementary files (see additional downloads for this article)**